

DCT4 Common Baseband

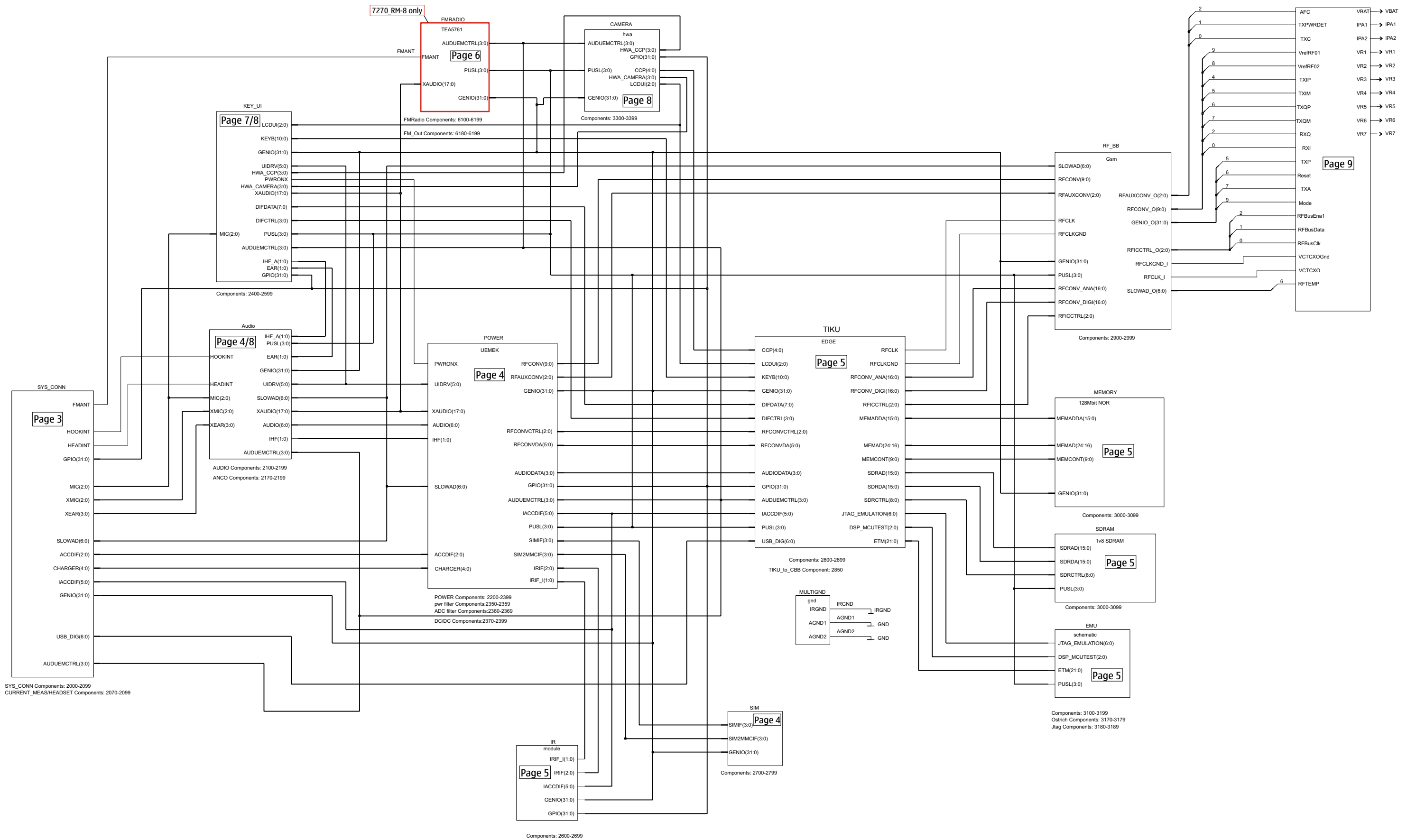

# System Connector and USB

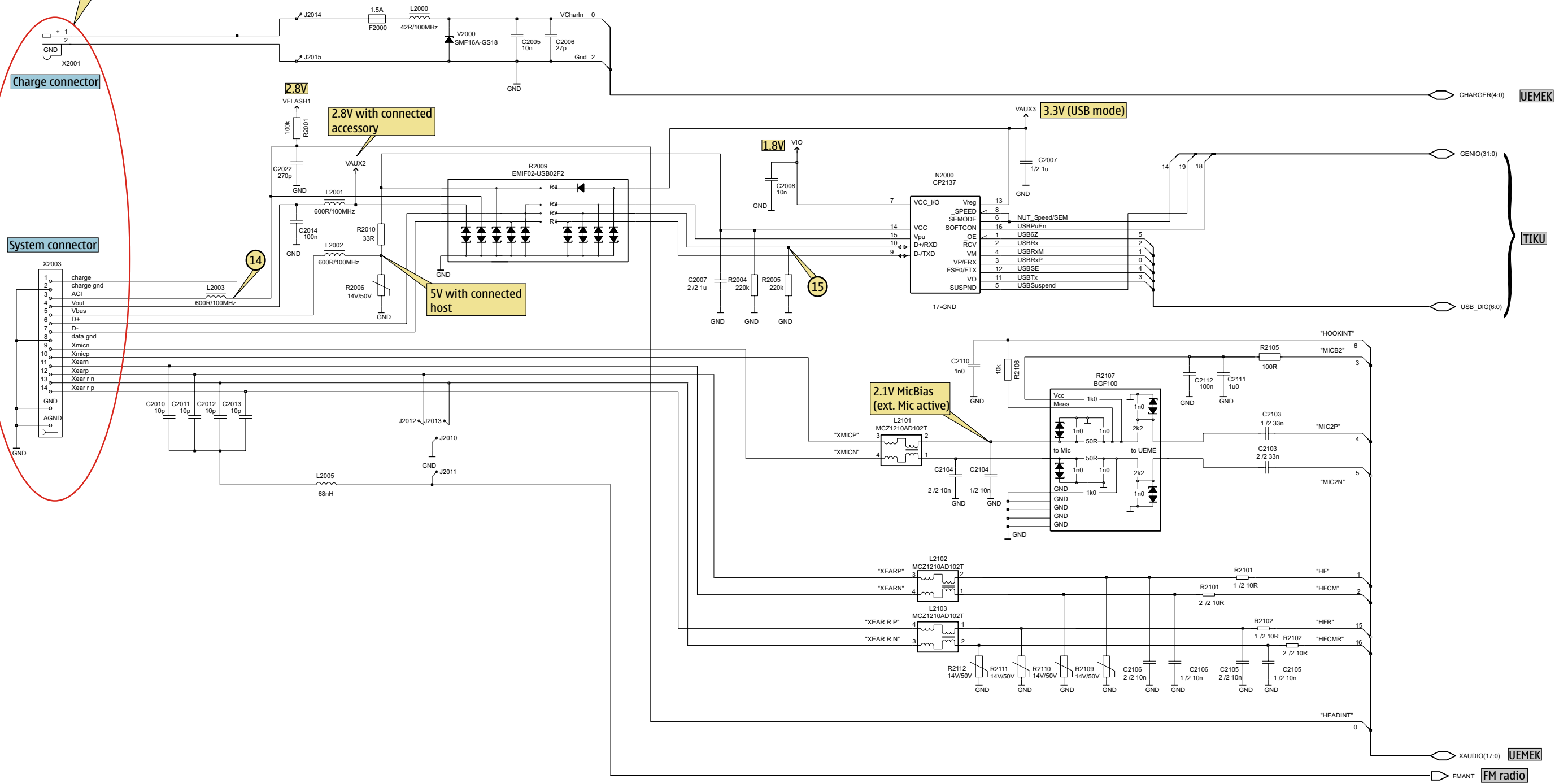
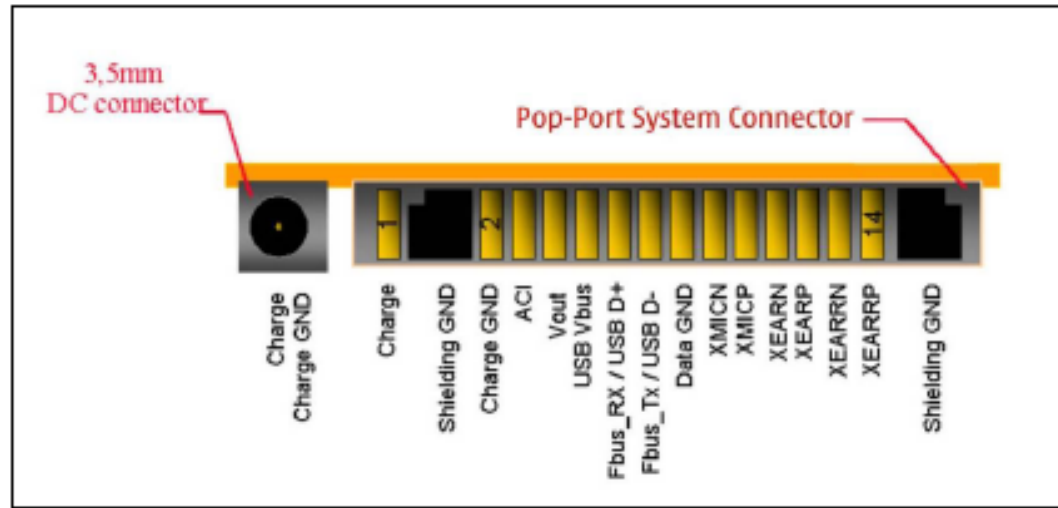

# UEME, SIM, ZOCUS and Audio

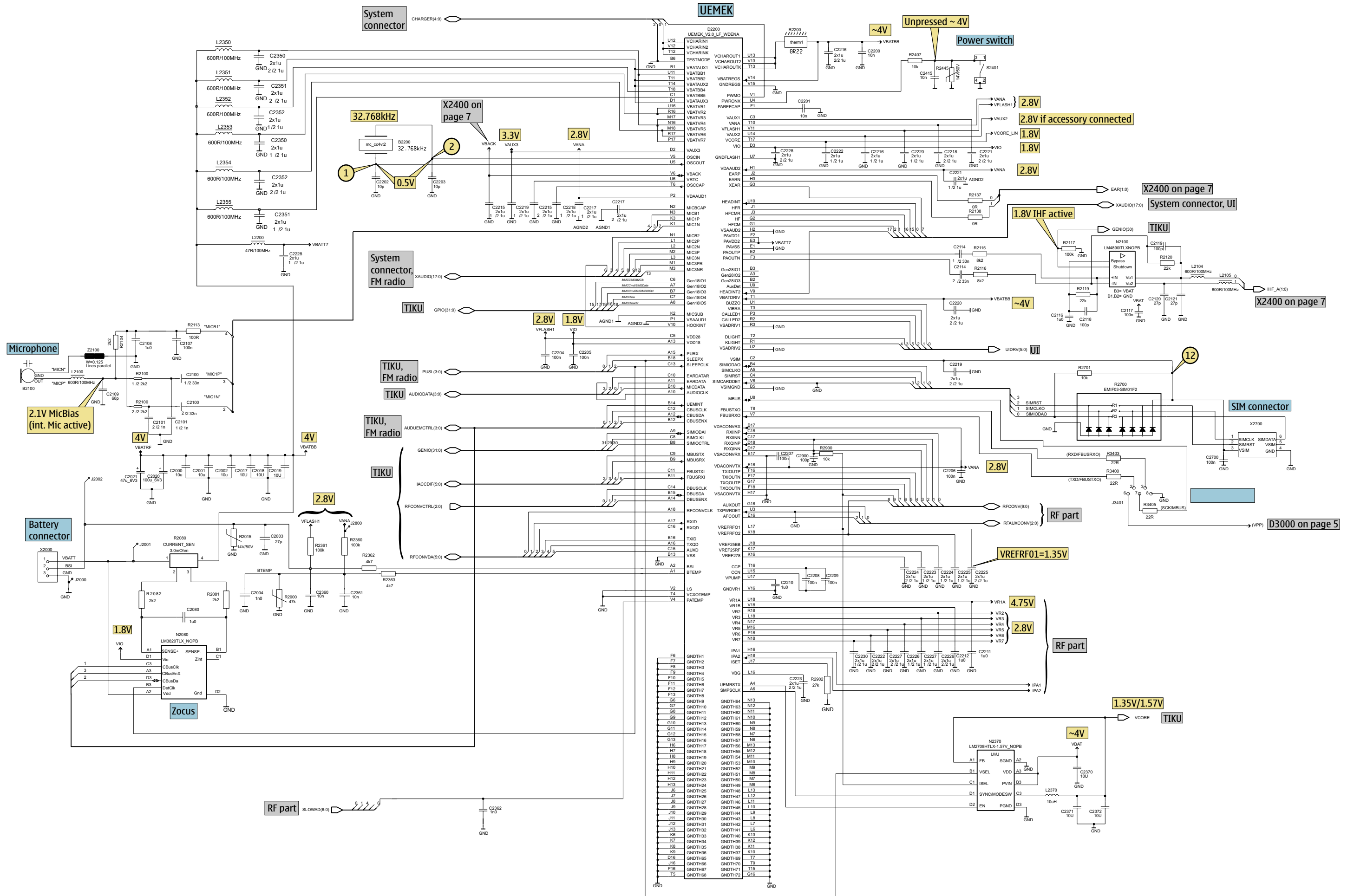

TIKU, SDRAM, Flash and IRDA

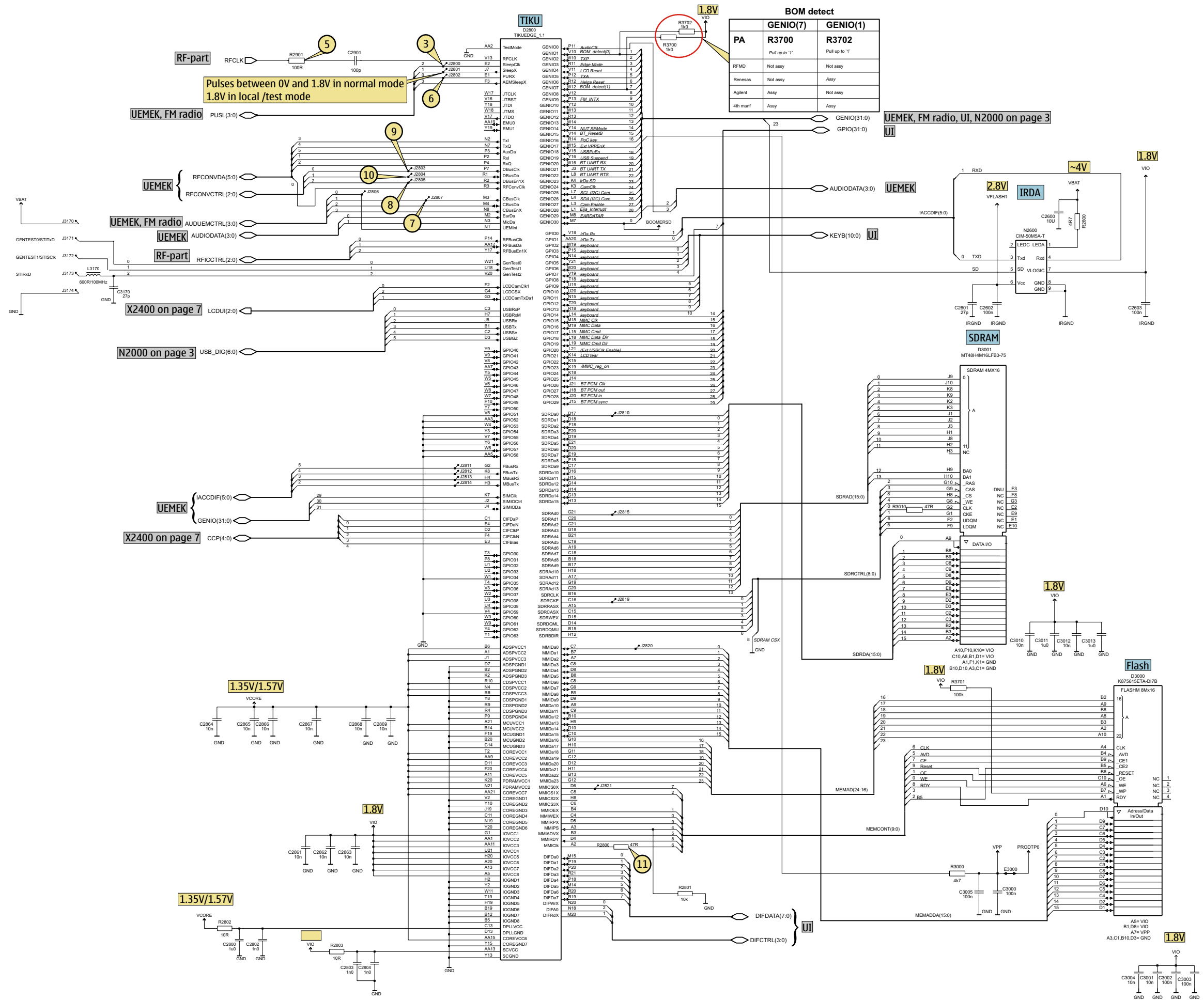

FM Radio

Only 7270 RM-8

Both 6170/7270

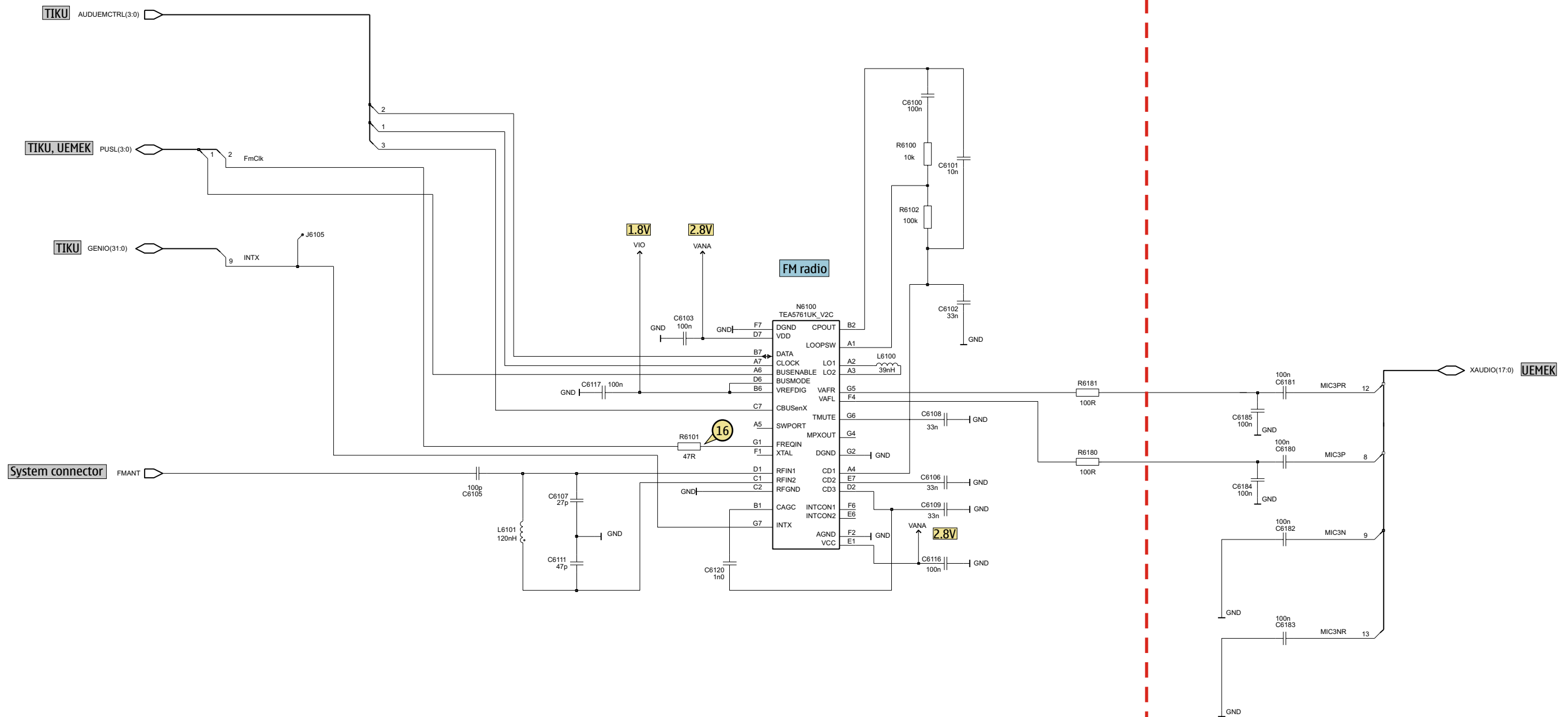

# Domesheet Keyboard and Vibra

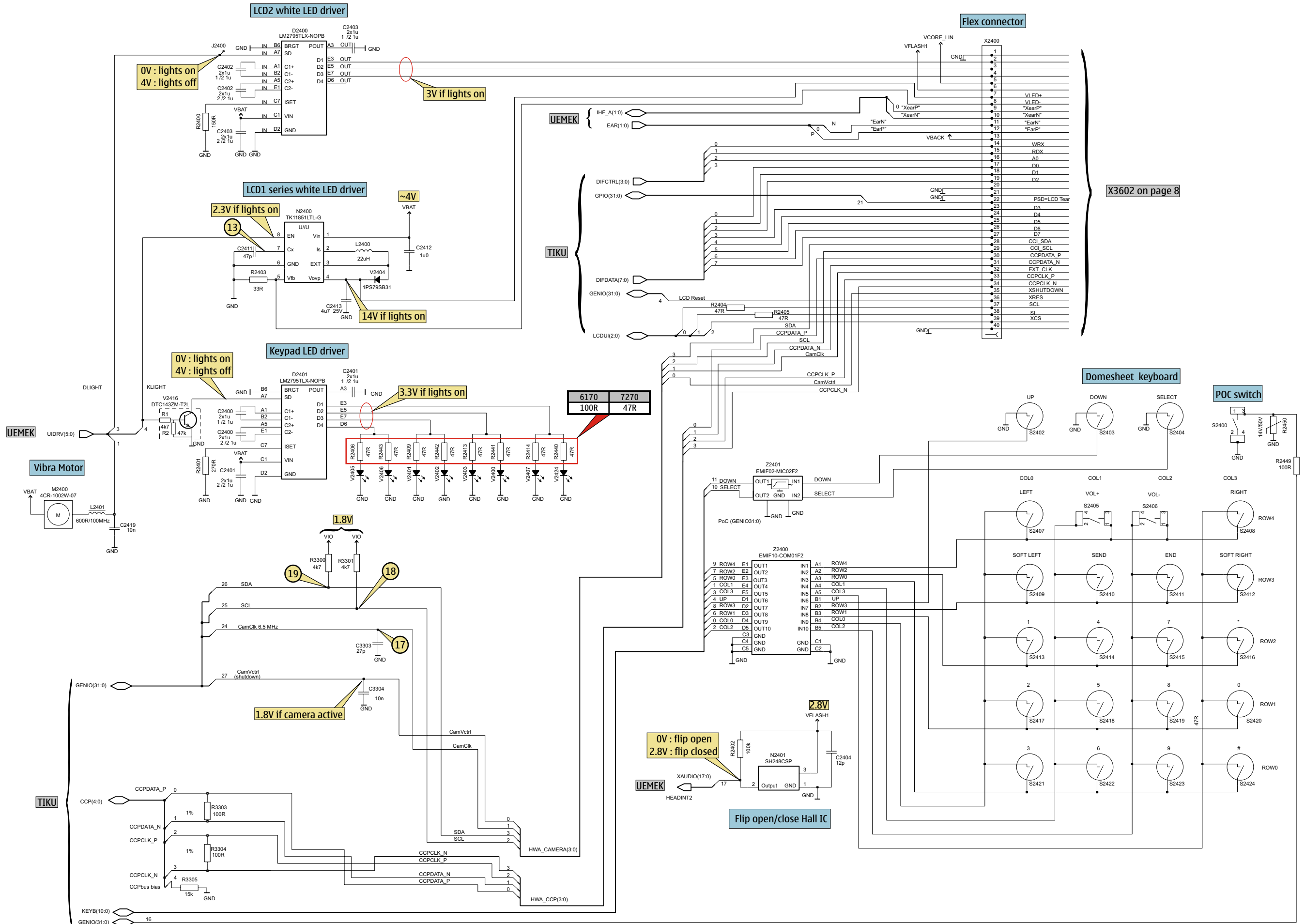

X3602 on page 8

# Upper Block

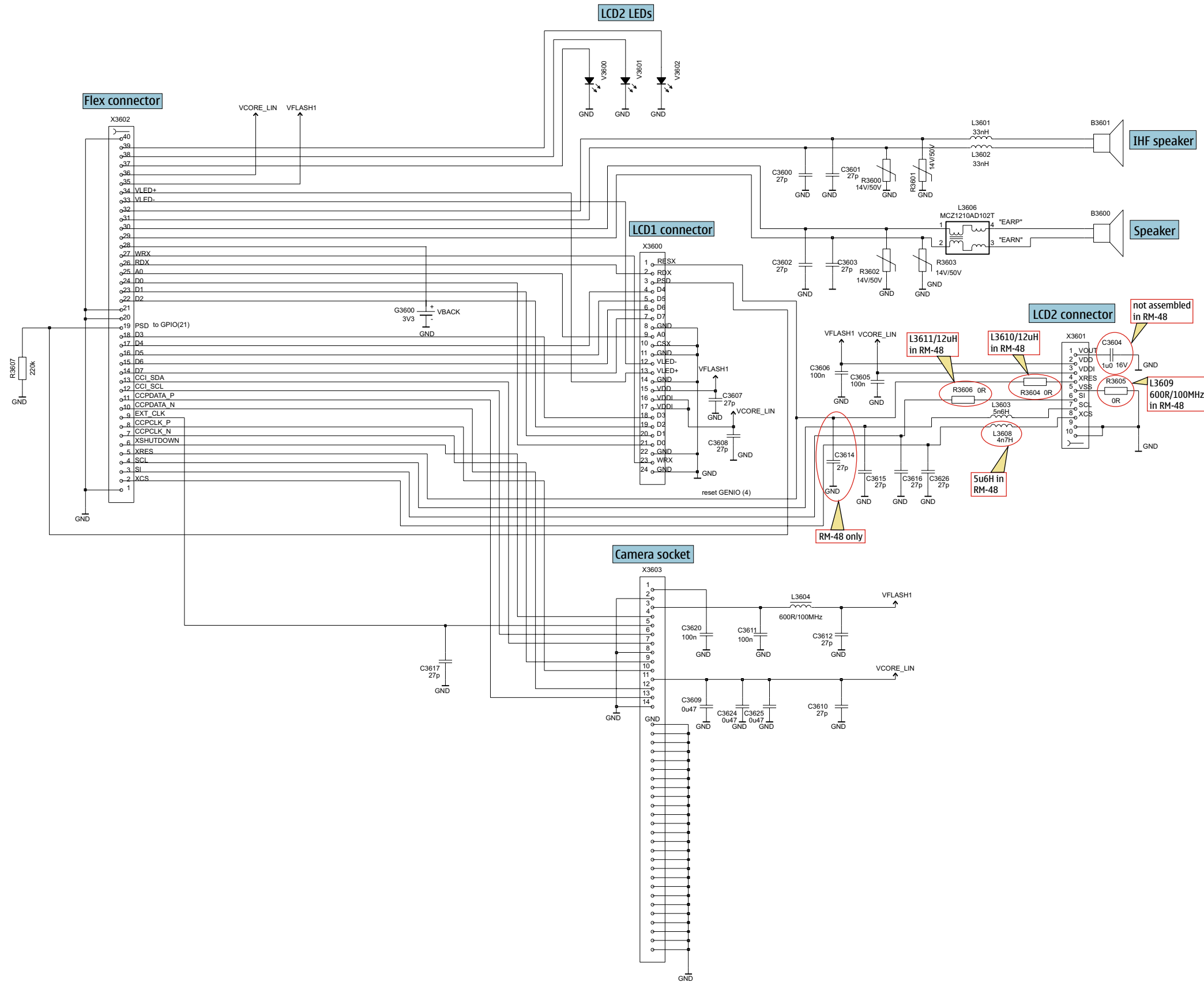



RF Part

	Vc1	Vc2	Vc3
GSM 850/900 RX	-	-	-
GSM1800 RX	-	-	-
GSM1900 RX	-	2.7Vpp	-
GSM 850/900 TX	-	2.7Vpp	2.7Vpp
GSM1800 TX	2.7Vpp	2.7Vpp	-
GSM1900 TX	2.7Vpp	2.7Vpp	-

Band	Channel	RX	VCO/RX	TX	VCO/TX
GSM850	190	881.6MHz	3526.4MHz	836.6MHz	3346.4MHz
EGSM 900	37	942.4MHz	3769.6MHz	897.4MHz	3589.6MHz
GSM 1800	700	1842.8MHz	3685.6MHz	1747.8MHz	3495.6MHz
GSM 1900	661	1960MHz	3920MHz	1880MHz	3760MHz

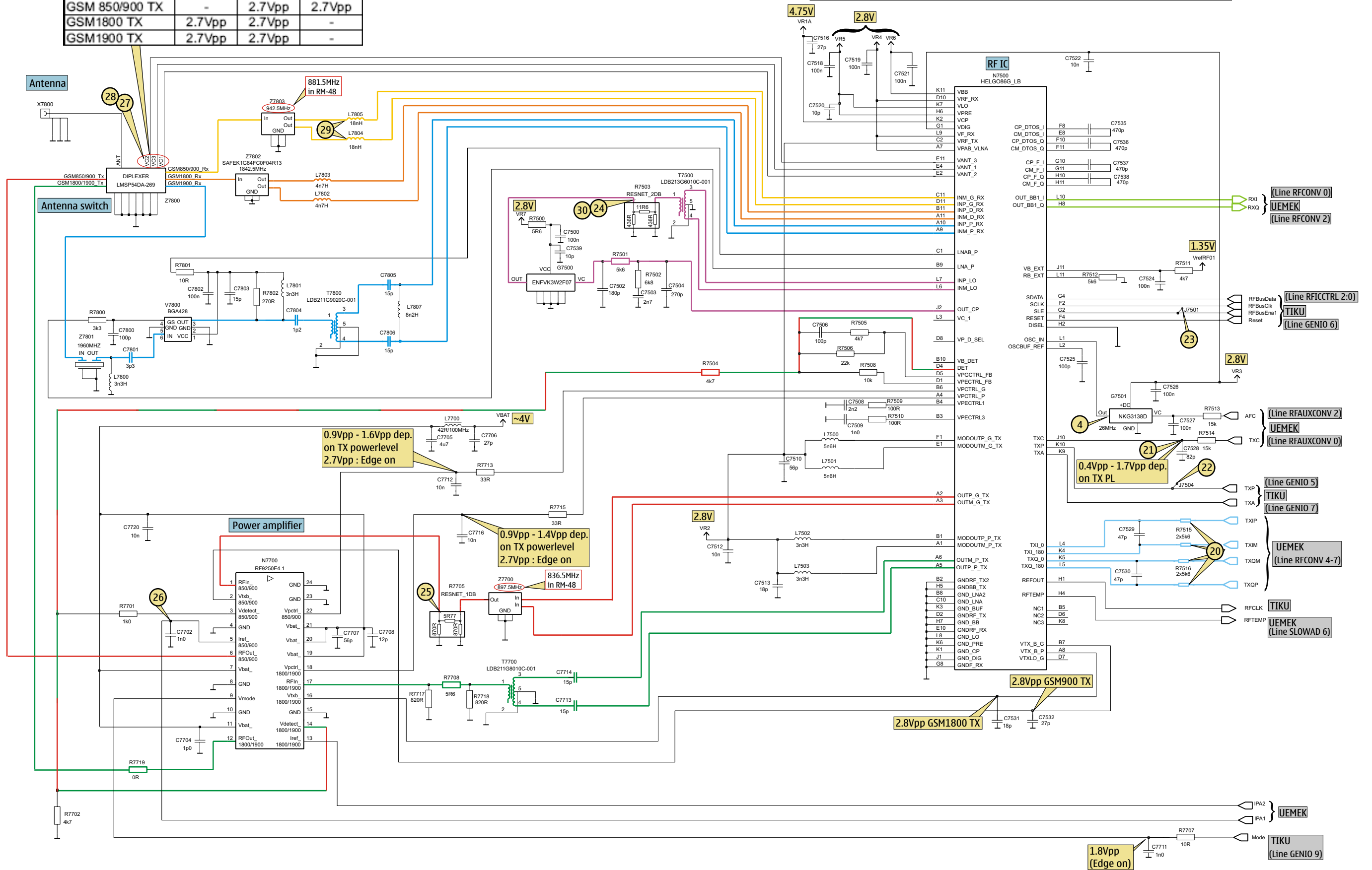



# Signal Overview

<p>1) 32.768kHz at C2202</p>	<p>2) 32.768kHz at C2203</p>	<p>3) Sleepclock at J2800</p>	<p>4) 26MHz clock at G7501 out</p>
<p>5) 26MHz RFLCK at C2901</p>	<p>6) PWRONX vs. PURX at J2802</p>	<p>7) CBUSCLK at J2807</p>	<p>8) DBUSENA at J2805</p>
<p>9) DBUSCLK at J2803</p>	<p>10) DBUSDATA at J2804</p>	<p>11) Flashclock at R2800</p>	<p>12) VSIM at C2219</p>
<p>13) SMPS CLK at C2411</p>	<p>14) ACI at L2003</p>	<p>15) D+ at R2005</p>	<p>16) FMCLK at R6101</p>
<p>17) 6.5MHz CAMCLK at C3303</p>	<p>18) SCL (camera) at R3301</p>	<p>19) SDA (camera) at R3300</p>	<p>20) TX I/Q at C7529 &amp; C7530</p>
<p>21) TXC at C7528</p>	<p>22) TXP at J7504</p>	<p>23) RFBUSENA at J7501</p>	<p>24) 3589.6MHz at G7503 (GSM900 TX)</p>
<p>25) 897.4MHz at R7705 (GSM900 TX)</p>	<p>26) IPA1 at C7702 (Edge on)</p>	<p>27) VC2 GSM1900 TX at Z7800</p>	<p>28) VC2 GSM1900 RX at Z7800</p>
<p>29) 942.4MHz GSM900 RX at Z7803</p>	<p>30) 3769.6MHz at R7503 GSM900 RX</p>		

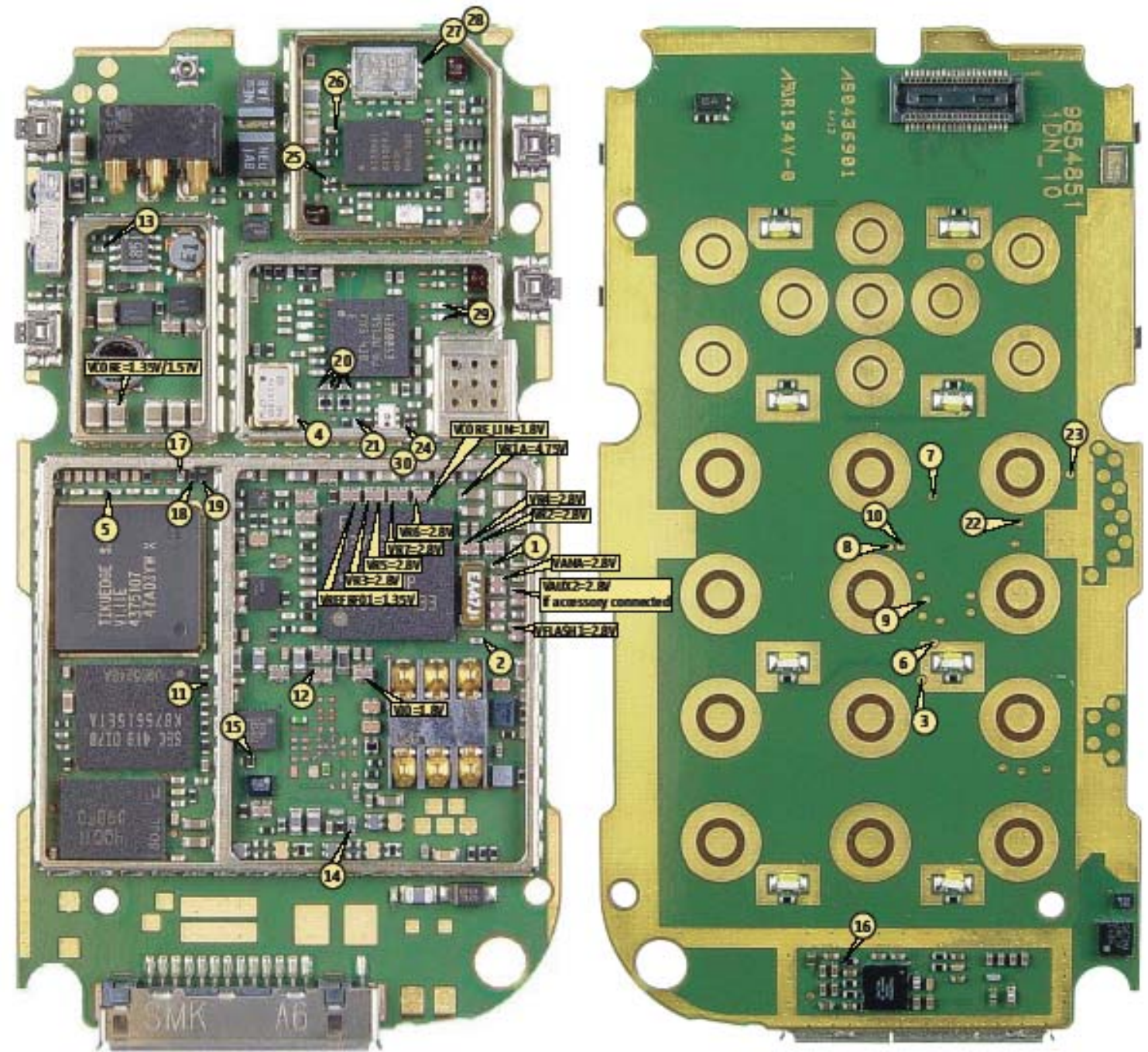



# Component Finder

B	C2228	K4	C6182	J3	J2010	N8	L7803	D2	R2700	L1	V2404	E7	
B2200	I2	C2230	H3	C6183	J4	J2011	O8	L7804	E2	R2701	L1	V2405	D6
C	C2350	H4	C6184	O4	J2012	N7	L7805	E2	R2800	K6	V2406	D3	
C2000	H1	C2351	K5	C6185	P4	J2013	N7	L7807	E3	R2801	K6	V2407	J6
C2001	H1	C2352	H2	C7500	F2	J2014	N2	N	R2802	K8	V2416	I5	
C2002	H1	C2360	I4	C7502	G1	J2015	N3	N2000	K5	R2803	G7	V2424	J3
C2003	C6	C2361	J4	C7503	G2	J2400	D6	N2080	D5	R2900	I4	V7800	B2
C2004	J5	C2362	J1	C7504	F2	J2800	K5	N2100	H5	R2901	G7	X	
C2005	M2	C2370	E7	C7506	D5	J2801	I6	N2370	E7	R2902	H4	X2000	B7
C2006	M3	C2371	G8	C7508	D4	J2802	J6	N2400	D7	R3000	L6	X2003	O5
C2007	M5	C2372	G7	C7509	E5	J2803	I6	N2401	B2	R3010	L8	X2400	B6
C2008	K6	C2400	I5	C7510	E5	J2804	I5	N2600	D8	R3300	G6	X2700	K2
C2010	O7	C2401	I5	C7512	E5	J2805	I5	N6100	O5	R3301	G6	X3499	C8
C2011	O7	C2402	E6	C7513	E5	J2806	I5	N7500	E3	R3303	K6	X7800	A6
C2012	O7	C2403	E6	C7516	F4	J2807	H6	N7700	C3	R3304	K6	Z	
C2013	O7	C2404	B2	C7518	F4	J2810	M6	R	R3305	J6	Z2400	O8	
C2014	M4	C2411	D8	C7519	F3	J2811	J6	R2000	O4	R3400	M2	Z2401	N9
C2017	G7	C2412	E7	C7520	F4	J2812	H7	R2001	M4	R3403	M2	Z7700	C4
C2018	G6	C2413	D8	C7521	F3	J2813	J6	R2004	M5	R3405	M2	Z7800	A3
C2019	G6	C2415	E9	C7522	F4	J2814	J6	R2005	L5	R3701	L6	Z7801	A2
C2020	B5	C2419	J5	C7524	F4	J2815	M8	R2006	M5	R6100	O6	Z7802	D2
C2021	C5	C2600	B8	C7525	F4	J2819	L7	R2009	L5	R6101	O4	Z7803	E2
C2022	M4	C2601	C8	C7526	F5	J2820	L7	R2010	M5	R6102	O6		
C2080	C5	C2602	C8	C7527	F5	J2821	L7	R2015	C6	R6180	O4		
C2100	K3	C2603	E8	C7528	G4	J3170	L8	R2081	C5	R6181	O4		
C2101	K3	C2700	L1	C7529	F4	J3171	K8	R2082	C5	R7500	F2		
C2103	K1	C2800	K8	C7530	F4	J3172	K8	R2100	L3	R7501	G2		
C2104	M3	C2802	K8	C7531	D2	J3173	K8	R2101	M3	R7502	G2		
C2105	M5	C2803	G7	C7532	C4	J3174	L8	R2102	M4	R7503	G3		
C2106	M3	C2804	G7	C7535	E3	J3180	G8	R2104	L3	R7504	D5		
C2107	M3	C2861	G8	C7536	F3	J3181	G8	R2105	K1	R7505	D4		
C2108	L3	C2862	H8	C7537	F3	J3182	G8	R2106	K1	R7506	E4		
C2109	L3	C2863	G8	C7538	F3	J3183	H8	R2107	K1	R7508	D5		
C2110	K1	C2864	K5	C7539	F2	J3184	H8	R2109	M4	R7509	D4		
C2111	K1	C2865	H7	C7702	B4	J3185	H9	R2110	M4	R7510	D5		
C2112	K1	C2866	H7	C7704	B3	J3186	H8	R2111	M5	R7511	G3		
C2114	H5	C2867	H8	C7705	B4	J3187	H9	R2112	M5	R7512	F3		
C2116	G5	C2868	G8	C7706	A4	J3188	I8	R2113	L3	R7513	F5		
C2117	G5	C2869	G8	C7707	C4	J3189	I8	R2115	H5	R7514	G4		
C2118	H5	C2900	H4	C7708	C4	J3401	M2	R2116	H5	R7515	F4		
C2119	H5	C2901	H7	C7711	C2	J6105	O4	R2117	H5	R7516	F4		
C2120	H5	C3000	L6	C7712	C4	J7501	G8	R2119	H5	R7701	B4		
C2121	H5	C3001	L6	C7713	C2	J7504	H7	R2120	H5	R7702	B4		
C2200	I1	C3002	L6	C7714	D2	L	R2137	K5	R7705	C4			
C2201	J5	C3003	M6	C7716	C2	L2000	N3	R2138	L4	R7707	C2		
C2202	I1	C3004	M6	C7720	D4	L2001	M4	R2200	I1	R7708	C3		
C2203	J2	C3005	L6	C7800	B2	L2002	M5	R2360	J5	R7713	C4		
C2204	J1	C3010	M8	C7801	B2	L2003	M4	R2361	I4	R7715	C2		
C2205	I4	C3011	M6	C7802	B2	L2005	O7	R2362	J4	R7717	C3		
C2206	I4	C3012	M6	C7803	B2	L2100	L4	R2363	J5	R7718	C3		
C2207	I4	C3013	M6	C7804	C2	L2351	J5	R2400	E7	R7719	B2		
C2208	H2	C3170	K8	C7805	D3	L2352	H2	R2401	I5	R7800	B2		
C2209	H2	C3303	G6	C7806	D3	L2353	H5	R2402	B2	R7801	B2		
C2210	H3	C3304	H6	D	L2354	H3	R2403	D8	R7802	C2			
C2211	H2	C6100	O6	D2200	I3	L2355	J5	R2404	H8	S			
C2212	H2	C6101	O6	D2400	E6	L2370	F7	R2405	G8	S2400	B8		
C2215	J1	C6102	O6	D2401	I5	L2400	D6	R2406	C6	S2401	E8		
C2216	I1	C6103	O4	D2800	I7	L2401	J5	R2407	E8	S2405	B1		
C2217	I2	C6105	O7	D3000	K7	L3170	L8	R2409	F6	S2406	E1		
C2218	I1	C6106	O4	D3001	M7	L6100	O5	R2413	N6	T			
C2219	K4	C6107	O5	F	L6101	O7	R2414	K6	T7500	G3			
C2220	J1	C6108	O4	F2000	N3	L7500	E4	R2440	K3	T7700	C3		
C2221	J4	C6109	P6	G	L7501	E4	R2441	N3	T7800	C2			
C2222	H3	C6111	O5	G7500	F2	L7502	E4	R2442	F3	V			
C2223	H4	C6116	P4	G7501	F5	L7503	E4	R2443	C3	V2000	N2		
C2224	H4	C6117	P5	J	L7700	B4	R2445	E8	V2400	N3			
C2225	H4	C6120	O6	J2000	A7	L7800	B2	R2449	B8	V2401	F6		
C2226	I2	C6180	O4	J2001	A7	L7801	C2	R2450	B8	V2402	F3		
C2227	H3	C6181	O4	J2002	A8	L7802	E2	R2600	C8	V2403	N6		

